

# e-ZGO™ SERIES



Ergonomics matter – whether work occurs at the office or at home. At the same time, products built for the traditional office are designed to meet a broad range of performance standards and often reflect the price points necessary to achieve these requirements. However, when working from home, we should be able to choose products that offer exactly what we need and at prices that fit our budget. Why pay for performance and features that aren't necessary?

ZGO listened, and we are excited to offer a portfolio of height adjustable tables that deliver the right performance at the right price, and ready to ship right to the home. The e-ZGO™ series products are based on ZGO's high performing, commercial grade product designs which have been optimized for Work From Home applications.

## Series 22

Designed with commercial grade performance for the home environment, Series 22 rises to the occasion. This 2-stage frame with a traditional column design is powered by two motors which deliver 120kg (264 lbs.) of load capacity. Performance without compromise.

### Commercial Performance:

A dual stage, dual motor table with performance that is suitable for a commercial and residential environment. Series 22 offers an electric lift up to 120kg/264 lbs. and a travel speed of 36mm/1.4" per second.

### Traditional Design:







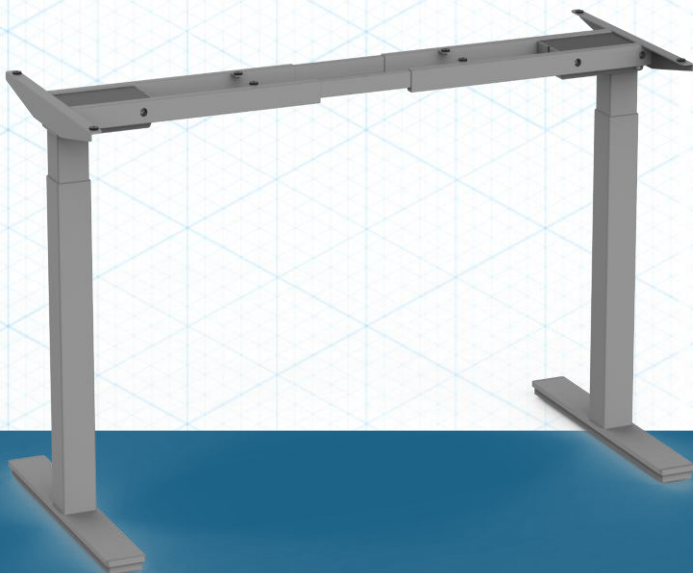

The rectangular or square, traditional column (large tube at the bottom/small tube at the top of the column) features a 480mm/18.9" stroke and an overall travel range from 690-1170mm / 27.2-46.1". The expandable frame accommodates the most common table top shapes & sizes from 24x48" to 30x60".





### Performance without Compromise:

Series 22 is an entry level, UL 962 approved frame that offers all the necessary features for a work from home desk. Features like 3 memory positions, anti-collision, and gyro-scope safety technology are included as standard options. Available in ISTA 3A certified packaging to ensure safe, drop shippable parcels wherever and whenever you need them.



Features	Specs
----------	-------

	Leg Quantity	2 Leg
	Leg Stage	2 Stage
	Leg Size	80x50mm / 3.15x1.97" 70x70mm / 2.76 x 2.76"
	Stroke	480mm / 18.9"
	Height Range	Standard: 690-1170mm / 27.2-46.1"
	Top Frame	1000-1500mm / 39.4-59.1"
	End Pipe	500mm / 19.7"
	Speed	36mm / 1.4" per second
	Load Capacity	120kg / 264 lbs.

	Column Foot Connection	T or C Leg
	Feet Length	600mm / 23.6"
	Feet Type	90D Aluminum
	Remote Control	6 button programmable

**6 Button Programmable Remote Control**



**90D Aluminum Foot Type**

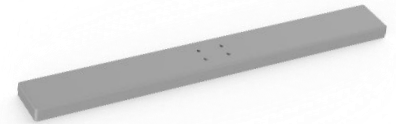

### Ordering Key

Series22 - S - T - 012

Color code	012 = White 013 = Gray 014 = Black
Foot code	T = T Leg C = C Leg
Column code	S = Square Column (70x70mm/2.76x2.76") R = Rectangle Column (80x50mm/3.15x1.97")
Frame code	Series 22 = Traditional column (large tube down)

Standard in smooth finish:



#### AMERICAS

(616) 499-7995  
9:00am - 5:00pm (EST) | M-F  
820 Monroe Ave NW Suite 160  
Grand Rapids, MI 49503

#### ASIA PACIFIC

+86 021 5778 6203  
9:00am - 5:00pm (CST) | M-F  
13A Floor Fengyuan Building, No. 909  
Xinsongjiang Road, Songjiang  
Shanghai, China 201620  
P.R.C. China

#### EUROPE

+45 31 11 00 11  
9:00am - 5:00pm (CET) | M-F  
Borupvang 3, 2750  
Balleup, Denmark